



# TIP42C

## 用途

- 应用于中功率线性转换电路

## 产品特性

- 高集电极电压:  $V_{CEO}=-100V$  (min)
- 与 TIP41C 互补
- 环保 (RoHS) 产品

## APPLICATIONS

- Medium Power Linear Switching Applications

## FEATURES

- High collector voltage:  $V_{CEO}=-100V$  (min)
- Complementary to TIP41C
- RoHS product

## 封装 Package

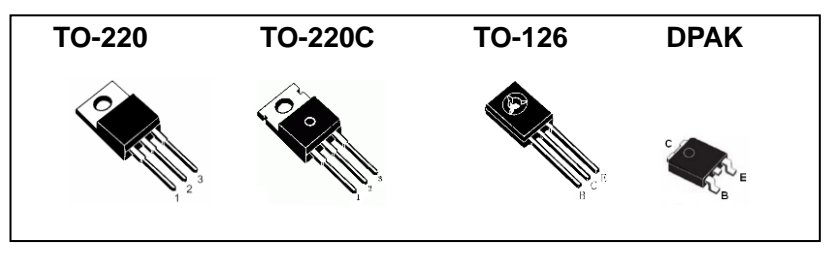
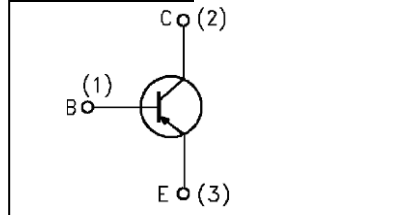

## 订货信息 ORDER MESSAGE

订货型号 Order codes						印 记 Marking	封 装 Package
有卤-条管 Halogen-Tube	无卤-条管 Halogen Free-Tube	有卤-袋装 Halogen-Reel	无卤-袋装 Halogen Free-Reel	有卤-编带 Halogen-Reel	无卤-编带 Halogen Free-Reel		
TIP42C-CA-B	N/A	N/A	N/A	N/A	N/A	TIP42C	TO-220
TIP42C-C-B	N/A	TIP42C-C-C	N/A	N/A	N/A	TIP42C	TO-220C
TIP42C-R-B	N/A	TIP42C-R-C	N/A	TIP42C-R-A	TIP42C-R-AR	TIP42C	TO-126
TIP42C-M-B	TIP42C-M-BR	TIP42C-M-C	TIP42C-M-CR	N/A	N/A	TIP42C	DPAK

## 绝对最大额定值 ABSOLUTE RATINGS ( $T_c=25^\circ\text{C}$ unless otherwise noted)

项 目 Parameter	符 号 Symbol	数 值 Value	单 位 Unit	
集电极—基极直流电压	Collector-Base Voltage ( $I_e = 0$ )	$V_{CBO}$	-100	V
集电极—发射极直流电压	Collector- Emitter Voltage ( $I_B=0$ )	$V_{CEO}$	-100	V
发射极—基极直流电压	Emitter-Base Voltage	$V_{EBO}$	-5	V
最大集电极直流电流	Collector Current (DC)	$I_C$	-6	A
最大集电极脉冲电流	Collector Current (Pulse)	$I_{CP}$	-10	A
最大基极电流	Base Current	$I_B$	-2	A
最大集电极耗散功率	Collector Dissipation( $T_c=25^\circ\text{C}$ TO-220)	$P_C$	65	W
最大集电极耗散功率	Collector Dissipation( $T_a=25^\circ\text{C}$ )	$P_C$	2	W
最高结温	Junction Temperature	$T_j$	150	$^\circ\text{C}$
贮存温度	Storage Temperature	$T_{stg}$	-55~+150	$^\circ\text{C}$

**热特性 THERMAL CHARACTERISTIC**

项 目 Parameter	Symbo	min	max	Unit
结到环境的热阻 Thermal Resistance Junction Ambient TO-220(C)	$R_{th(j-a)}$	-	62.5	$^{\circ}\text{C}/\text{W}$
结到管壳的热阻 Thermal Resistance Junction Case TO-220(C)	$R_{th(j-c)}$	-	1.923	$^{\circ}\text{C}/\text{W}$
结到管壳的热阻 Thermal Resistance Junction Case TO-126	$R_{th(j-c)}$		6.25	$^{\circ}\text{C}/\text{W}$
结到管壳的热阻 Thermal Resistance Junction Case DPAK	$R_{th(j-c)}$		12.5	$^{\circ}\text{C}/\text{W}$

**电特性 ELECTRICAL CHARACTERISTIC**

项 目 Parameter	测试条件 Tests conditions	最小值 Value(min)	典型值 Value(typ)	最大值 Value(max)	单位 Unit
$V_{CE0}(\text{sus})$	$I_C=-30\text{mA}, I_B=0$	-100		-	V
$I_{CES}$	$V_{CE}=-100\text{V}, V_{EB}=0$	-	-	-400	$\mu\text{A}$
$I_{CEO}$	$V_{CE}=-60\text{V}, I_B=0$	-	-	-0.7	mA
$I_{EBO}$	$V_{EB}=-5\text{V}, I_C=0$	-	-	-1	mA
$h_{FE}^*$	$V_{CE}=-4\text{V}, I_C=-0.3\text{A}$	30			-
	$V_{CE}=-4\text{V}, I_C=-3.0\text{A}$	15		75	-
$V_{CE(\text{sat})}^*$	$I_C=-6.0\text{A}, I_B=-0.6\text{A}$	-		-1.5	V
$V_{BE(\text{sat})}^*$	$I_C=-6.0\text{A}, I_B=-0.6\text{A}$	-		-2.0	V
$f_T$	$V_{CE}=-10\text{V}, I_C=-0.5\text{A}, f=1\text{MHz}$	3.0	-	-	MHz

\*Pulse Test:  $PW \leq 300\text{ms}$ , Duty Cycle  $\leq 2\%$ 



特征曲线 ELECTRICAL CHARACTERISTICS (curves)

hFE - I<sub>C</sub>

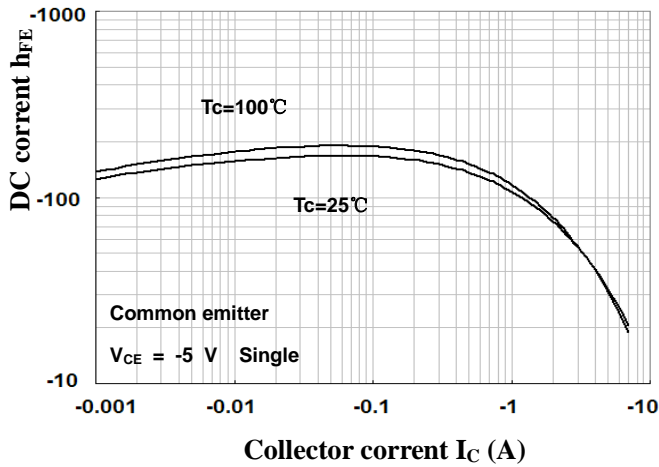

V<sub>CE(sat)</sub>- I<sub>C</sub>

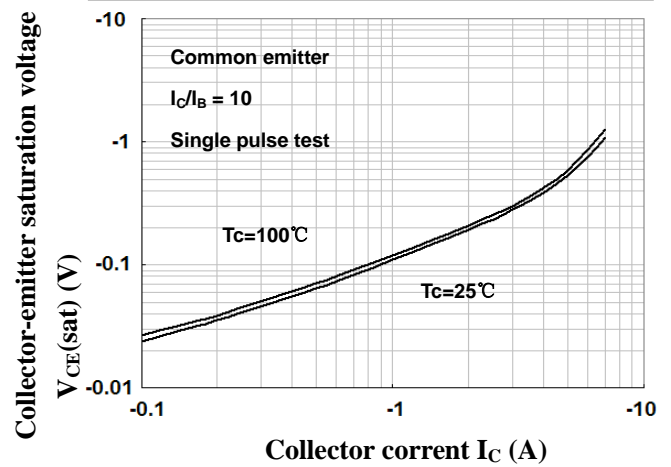

P<sub>C</sub>-T<sub>C</sub>

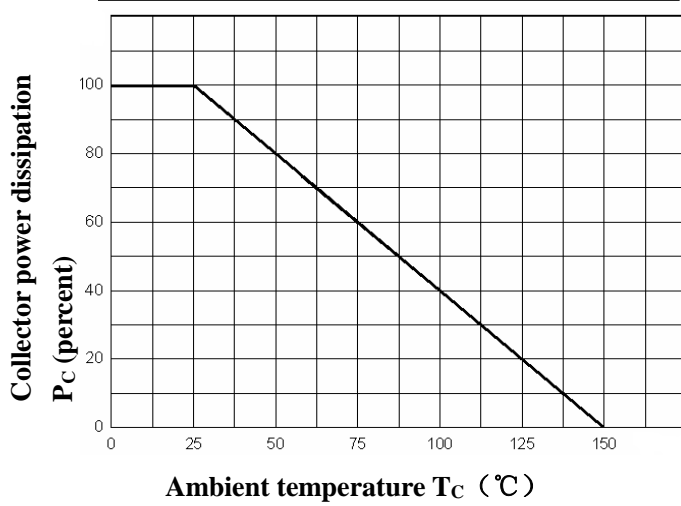

SOA

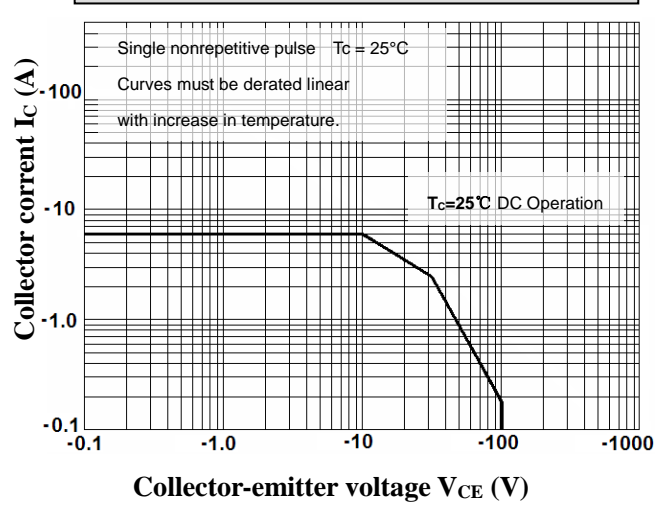



## 外形尺寸 PACKAGE MECHANICAL DATA

## TO-220

单位 Unit : mm

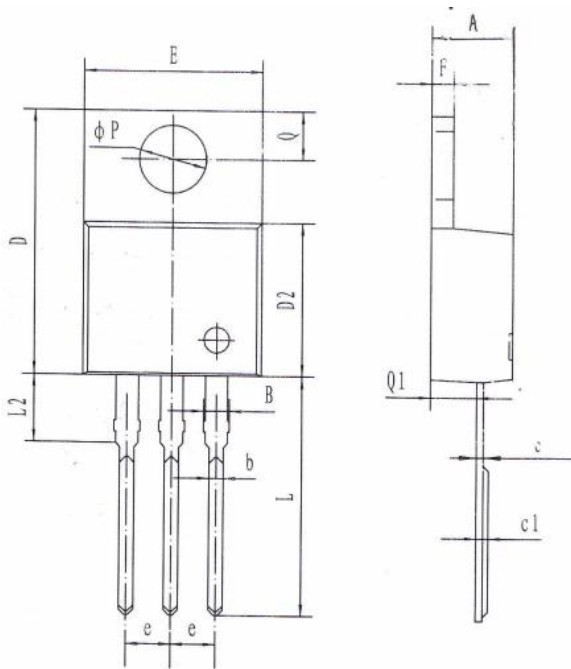

符号	尺寸 (mm)
A	4.40-4.80
B	1.10-1.40
b	0.70-0.95
c	0.28-0.48
c1	0.32-0.52
D	14.45-16.00
D2	8.20-9.20
E	9.60-10.40
e	2.39-2.69
F	1.20-1.35
L	13.05-14.05
L2	3.70-3.90
P	3.50-4.00
Q	2.40-3.00
Q1	2.20-2.90

## TO-220C

单位 Unit : mm

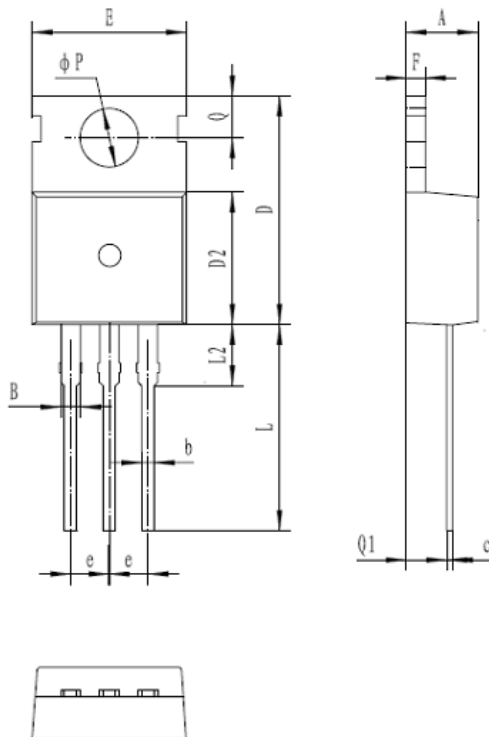

符号	尺寸 (mm)
A	4.30-4.70
B	1.10-1.40
b	0.70-0.95
c	0.40-0.65
D	15.20-16.20
D2	9.00-9.40
E	9.70-10.10
e	2.39-2.69
F	1.25-1.40
L	12.60-13.60
L2	2.80-3.20
P	3.50-3.80
Q	2.60-3.00
Q1	2.20-2.60





外形尺寸 PACKAGE MECHANICAL DATA  
DPAK

单位 Unit : mm

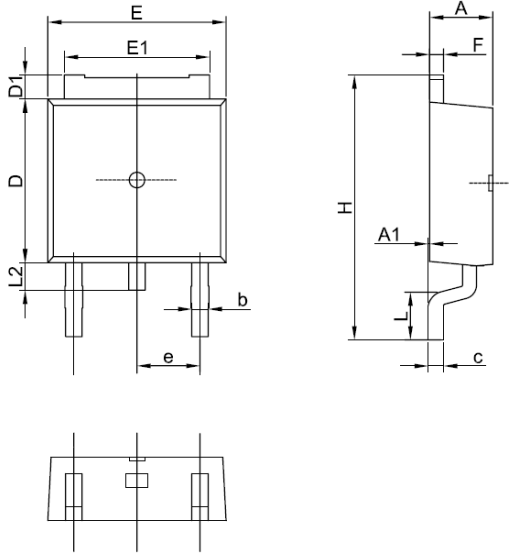

符号 Symbol	尺寸 (mm) Size (mm)
A	2.2-2.4
A1	0.0-0.2
b	0.7-0.9
c	0.45-0.55
D	6.0-6.3
D1	0.8-1.2
E	6.5-6.8
E1	5.2-5.5
e	2.28TYP
F	0.45-0.55
H	9.65-10.45
L	1.0-1.3
L2	0.7-1.3

外形尺寸 PACKAGE MECHANICAL DATA  
TO-126

单位 Unit : mm

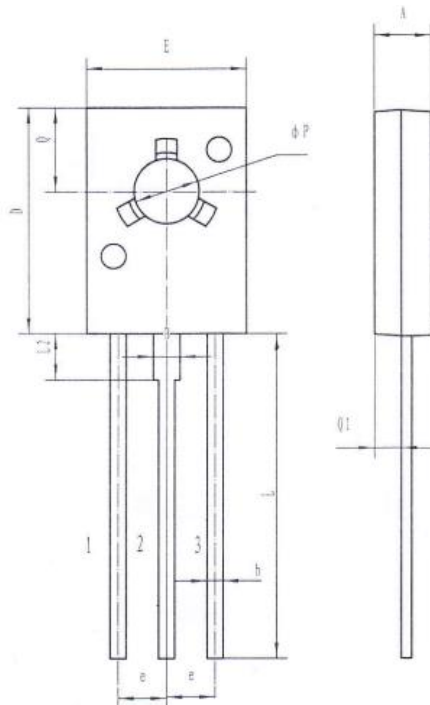

符号 Symbol	尺寸 (mm) Size (mm)
A	2.50-2.90
B	1.22-1.47
b	0.60-0.90
c	0.30-0.70
D	10.50-11.10
E	7.10-8.10
e	2.19-2.39
L	15.3-15.7
L2	2.10-2.30
Q	3.80-4.20
Q1	1.07-1.47
P	3.00-3.20

**注意事项**

1. 吉林华微电子股份有限公司的产品销售分为直销和销售代理，无论哪种方式，订货时请与公司核实。
2. 购买时请认清公司商标，如有疑问请与公司本部联系。
3. 在电路设计时请不要超过器件的绝对最大额定值，否则会影响整机的可靠性。
4. 本说明书如有版本变更不另外告知

**NOTE**

1. Jilin Sino-microelectronics co., Ltd sales its product either through direct sales or sales agent , thus, for customers, when ordering , please check with our company.
2. We strongly recommend customers check carefully on the trademark when buying our product, if there is any question, please don't be hesitate to contact us.
3. Please do not exceed the absolute maximum ratings of the device when circuit designing.
4. Jilin Sino-microelectronics co., Ltd reserves the right to make changes in this specification sheet and is subject to change without prior notice.

**联系方式****吉林华微电子股份有限公司**

公司地址：吉林省吉林市深圳街 99 号

邮编：132013

总机：86-432-64678411

传真：86-432-64665812

网址：[www.hwdz.com.cn](http://www.hwdz.com.cn)

**市场营销部**

地址：吉林省吉林市深圳街 99 号

邮编：132013

电话：86-432-64675588

64675688

64678411

传真：86-432-4671533

**CONTACT****JILIN SINO-MICROELECTRONICS CO., LTD.**

ADD: No.99 Shenzhen Street, Jilin City, Jilin Province, China.

Post Code: 132013

Tel: 86-432-64678411

Fax: 86-432-64665812

Web Site: [www.hwdz.com.cn](http://www.hwdz.com.cn)

**MARKET DEPARTMENT**

ADD: No.99 Shenzhen Street, Jilin City, Jilin Province, China.

Post Code: 132013

Tel: 86-432-64675588

64675688

64678411

Fax: 86-432-64671533





## 附录（Appendix）：修订记录（Revision History）

日期 Date	旧版本 Last Rev.	新版本 New Rev.	修订内容 Description of Changes
2013-7-31	201203A	201208B	题头勘误
2014-3-20	201208B	201403C	增加 TO-220C 外形
2014-11-18	201403C	201421D	VCBO 项目勘误
2019-1-2	201421D	201901E	增加订货代码
2019-3-21	201901E	201903F	增加 TO-126 DPAK 外形

